

FiberForm lightweight parts The perfect combination of thermoforming and injection molding

Engineering Passion

Krauss Maffei

Facts and figures regarding FiberForm technology

Application areas



Automotive



Photo: TAKATA AG

Automotive



Automotive



Automotive

Processing matrix

1-step process

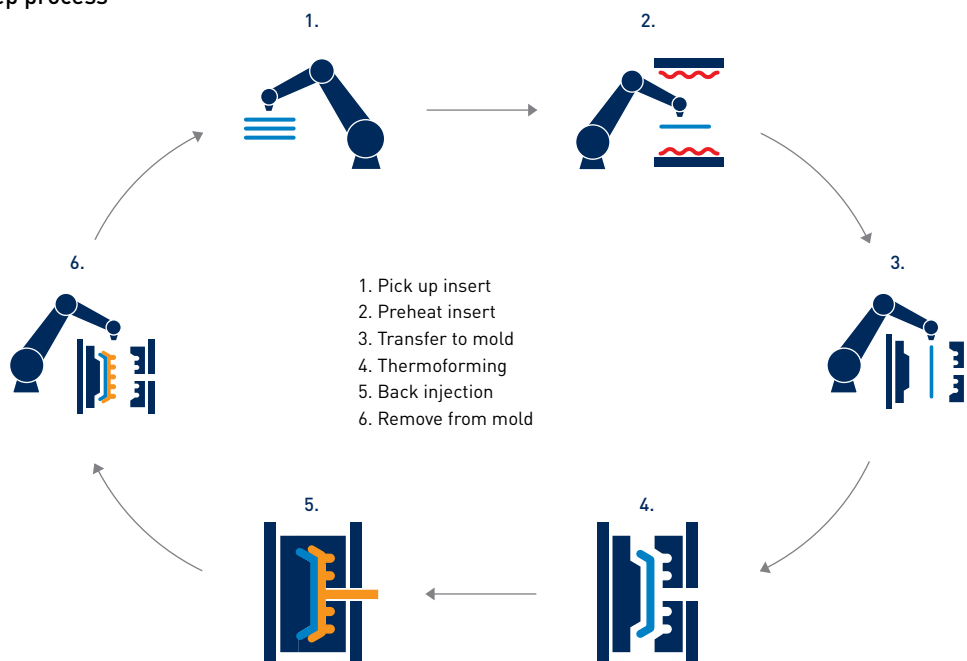

FiberForm lightweight parts **The perfect combination of thermo-** **forming and injection molding**

Parts used as alternatives to metal or traditional thick-walled plastic parts need to be lightweight yet highly functional. These days, conserving resources is a top priority and lightweight functional parts are therefore highly sought-after, particularly in the automotive industry.

FiberForm technology by KraussMaffei enables you to produce complex structural components using a fully automated process – efficiently and with noticeably short cycle times. The combination of thermoforming one or several semifinished products (organic sheets, thermoplastic tapes, etc.) and injection molding thermoplastic materials opens up completely new design possibilities and therefore market potential.

Your advantages:

- Lightweight parts
- Structural stiffness
- Completely closed part seam
- Great potential for integrating functions
- Fully automatic and fully reproducible manufacturing process
- System and process expertise from a single source
- Extensive network of material producers, semifinished-product suppliers, tool makers and further and higher education institutions

Transparent engineering FiberForm technology



Vehicle cross member, sample component
Made using FiberForm technology from a multilayer PA6 organic sheet with a 47 volume percent endless glass fiber content and over-molded with PA6 GF 60.

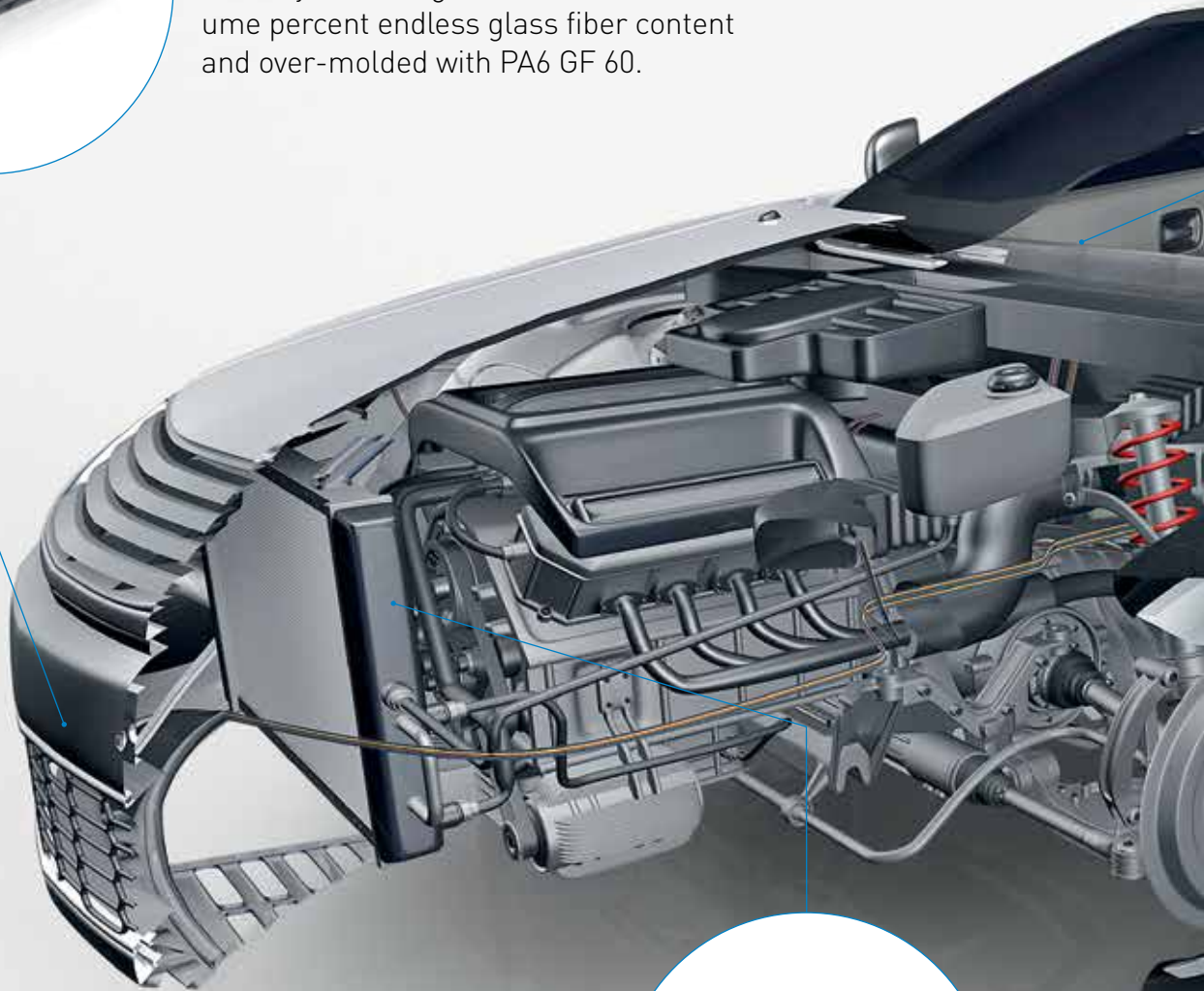

Vehicle front-end carrier, sample component
Partially reinforced with FiberForm technology from PP organic sheet over-molded with directly compounded PP LGF 30. PA6 organic sheet and PA LGF 30 can also be used.

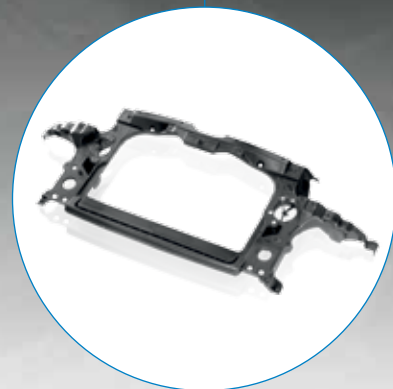

Vehicle airbag housing

Made using FiberForm technology from single-layer PA6 organic sheet with a 47 volume percent endless glass fiber content and over-molded with PA6 GF 40 copolymer that has been modified to be impact-resistant.



Photo: TAKATA AG

Vehicle seat shell

Made using FiberForm technology from multilayer PA6 organic sheet with a 47 volume percent endless glass fiber content and over-molded with PA6 GF copolymer that has been modified to be impact-resistant.



Vehicle door side impact beams, sample component

Made with FiberForm technology from multilayer PA6 organic sheet with a 47 volume percent endless glass fiber content, over-molded with PA6 GF 60. Molded bolt holes provide high-strength connections for adjoining structures.



One-step process – fast and cost-effective with no need for post-mold processing

Force-flow reinforcement for structural components

Using FiberForm technology maxes out the performance of fiber-reinforced thermoplastic injection-molded parts. Fabric made from endless fibers in a thermoplastic matrix, so-called "organic sheets" are heated in an integrated station, transferred into the injection mold when they are hot, thermoformed by closing the mold and finally over-molded with a thermoplastic material. Alternatively, preformed semifinished products, called "preforms", can be used.

The advantages of a one-step process

In the two-step process, the preforms are poured into the injection mold when they are cold or prewarmed. Both processes create hybrid high-performance composites with excellent strength properties using organic sheets and short or long fiber-reinforced thermoplastics. PP, PA, PPS, PEI or PEEK are used as matrix materials, whereas glass, carbon or aramide fibers are used as reinforcing materials.

It all depends on the combination

Professional component and mold design is the key factor because the areas of a functional component do not need the same mechanical performance. It is also essential to find the right combination of polymer and reinforcing fiber for both the organic sheet and the thermoplastic,

depending on requirements. This allows to significantly reduce the wall thickness of many components.

Adjustable strength

Parts should always be as light as possible and as heavy as necessary. Only by following this principle the potential material savings required by the automotive industry can be achieved. Single- and multi-layer long-fiber mats with a thickness of 0.5 mm per layer can be used and over-molded. Despite a fiber content of up to 90 percent, all fibers are fully wetted with the matrix polymer. The fiber mats do not contain any air voids. Organic sheets have specific functions and strengths depending on the fiber orientation and layer structure.

Structural components with thermoplastic matrix

FiberForm – concept and key advantages

- Parts reinforced using organic sheet or thermoplastic tapes with no need for post-mold processing
- Ribs, extension elements and edging directly molded
- Casting of high-strength junction elements

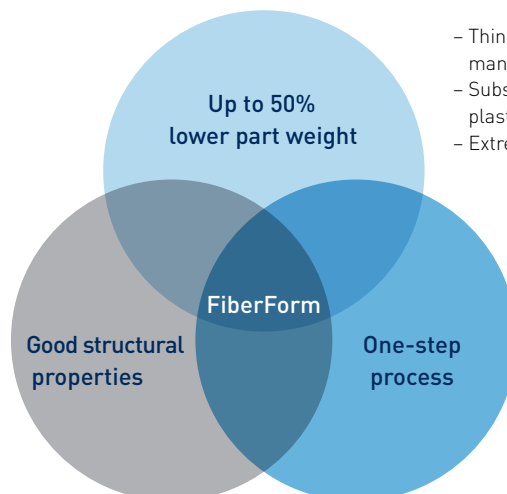

- Thinner walls than conventionally manufactured injection-molded parts
- Substitution of steel and aluminium with plastic parts reinforced by organic sheet
- Extremely strong structural components

- Preheating, thermoforming and trim-free over-molding in one production cell
- Expertise in automation systems and grippers
- Component-specific oven systems



Complex multifunction gripper for inserting, moving and demolding parts.

Versatile possibilities

The extremely high strength of the structural components is achieved not only through the right combination of plastic and fibers, but also through the shape of the injection-molded part. Additional reinforcements using ribs or even hollow structures can be added during the injection molding process. Extension elements and edging can also be integrated for further functions.

Fast and highly automated

The cycle times for making reinforced structural components are the same as those in conventional injection molding applications (approx. 60 seconds). The cooling time is what ultimately determines the overall cycle time. This makes FiberForm technology perfectly suited to use in very high-volume production. All FiberForm machines can be engineered as complete production cells, which have the advantage of being very compact and working in a fully automated way. There is no need for post-mold processing, such as part trimming, as parts are edged.

Advantages of combining both processes:

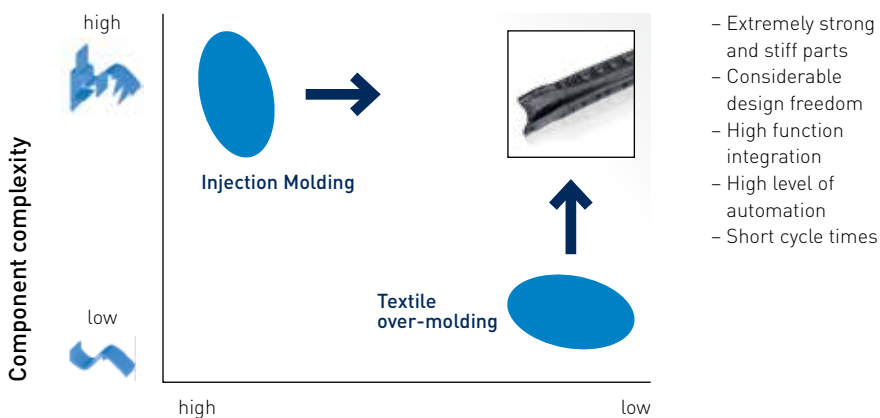

Achievable stiffness, strength and energy absorption capacity

Your advantages:

- Extremely strong structural components
- Choice of fiber and matrix for parts with optimum properties
- Ability to use fiber semifinished products with different thicknesses and fiber orientations
- Partially reinforced following force-flow design
- Automated production cell for preheating, molding, partially over-molding and edging parts
- Suitable for use in high-volume production without post-mold processing
- Special processing options for integrating functions

Turnkey production solutions From the raw material to the finished part



Turnkey production solutions essential for start of production

No other company has such extensive expertise in machines and technologies. There are numerous modules available for designing the fully automated production cell for your FiberForm application.

Preparing the organic sheet

A robot with a special multifunction gripper (vacuum and needles) transfers the organic sheet from the stacking unit to the specifically adapted heating station in a very precise way. The heating station is either a convection or infrared oven, depending largely on the geometry as well as the fiber and matrix materials of the part. Paternoster or throughput stations are also used when producing large parts. In the oven, the semifinished product is uniformly heated to the target tempera-

ture under constant conditions. Finally the robot transfers the now-formable semifinished product to the mold, where it is fixed in place exactly by hydraulic pick-up needles and/or partially spring-loaded retaining strips. At the same time, the robot removes the finished part from the previous cycle from the machine. The temperature of the organic sheet is precisely controlled and regulated by sensors in the oven and on the gripper during the transfer process.

Always the right injection molding machine

The extensive range of machines from KraussMaffei boasts hydraulic or electric injection molding machines with optimized injection units – able to handle clamping forces from 350 kN to 55,000 kN – to meet any processing requirements.

If you need a long fiber-reinforced material for back injection, the injection molding machine can be equipped with a long fiber plasticizing system or an injection molding compounder for direct processing.

No need for post-mold processing

As soon as the mold containing the hot organic sheet has closed and molding has taken place, the melt is fed into the mold via hot runners and the semi-finished product is over-molded in the desired geometry. Specially configured melt flow enhancers ensure that the corners of the mold are filled completely, the fibers surrounding the edge of the mold are encapsulated and possible voids in the organic sheet are also filled. Other functional parts can also be integrated during the injection molding process – without any need for post-mold processing.

Easy to operate

The machine and robot form a functional unit in the complete production cell. They work fully automatically and, thanks to the latest MC6 control system, can both be controlled via one control panel. Operating them is easy and even programming complex process sequences yourself does not require any specific additional knowledge.



Fully automatic handling of semifinished product and complete part

FiberForm mold components

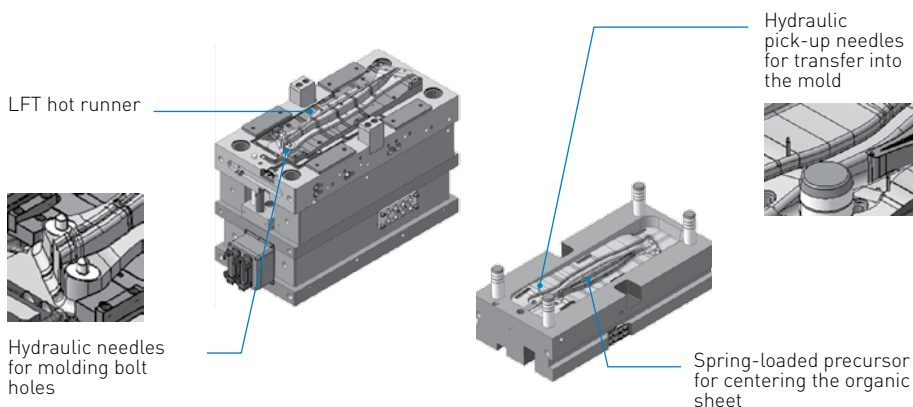

Your advantages:

- Fully automated overall concept
- Wide range of injection molding machines
- Multifunction gripper for central loading
- Innovative integrated heating technology
- Molding, casting and over-molding inside the mold
- Easy to use thanks to MC6 control system

Further information which might also interest you



Are you looking for detailed information about the right injection molding machine and automated solution for your application?

KraussMaffei boasts an extensive range of injection molding machines. Find out about our hydraulic CX, GX and MX Series or our fully electric AX and EX Series. We can offer you the right robot for every production task. You can also choose special tool clamping systems or other accessories for your injection molding machines.



We have also compiled extensive information on the subject of service for you.

With our servicing and maintenance services you can increase the flexibility of your injection molding machines to meet ever-changing process requirements and enhance their performance in the long term. We are happy to provide you with detailed information on this.

Ask us for information about the following, for example:

- Fiber composite solutions for sophisticated lightweight components
- High-pressure resin transfer molding
- Flexible tools for productive automation
- Industrial robots in the IR Series
- Direct compounding with the IMC injection molding compounder

You can find our brochures and flyers on other topics online at: www.kraussmaffei.com. On request, we would also be happy to send you information and technical data about our products free of charge.

KraussMaffei

A strong brand in a unique global group

Cross-technology system and process solutions

Whether in Injection Molding, Reaction Process Machinery or Automation – the KraussMaffei brand stands for pioneering and cross-technology system and process solutions in plastics processing worldwide. For decades, our expertise, innovative ability and passionate commitment to plastics engineering have been your competitive edge. As a cross-industry system provider, we offer you modular and standardized systems as well as solutions customized to your needs.

There for you around the world

With our worldwide sales and service network, we offer our international customers an excellent basis for a successful business relationship. Due to the close proximity to our customers, we are able to answer your individual inquiries very quickly. We work out the best possible technical and economical solution for your product and production requirements together with you. Test our machine technology for your applications and let our experts put together an individualized service package for you.

Individualized service

Our employees from customer service, application technology and service help you with your questions and needs on every topic dealing with machines, systems and processes – around the globe, quickly and with a high level of expertise. We have developed an extensive customized service spectrum with our lifecycle design, which accompanies you throughout the entire lifecycle of your machines and systems. Take advantage of the personal interaction and flexibility we offer in our practically oriented seminars. We carry out customer-specific trainings either at your location or at our sales and service locations.

KraussMaffei Group

Comprehensive expertise

Unique selling proposition Technology³

The KraussMaffei Group is the only provider in the world to possess the essential machine technologies for plastics and rubber processing with its KraussMaffei, KraussMaffei Berstorff and Netstal brands: Injection Molding Machinery, Automation, Reaction Process Machinery and Extrusion Technology.

The group is represented internationally with more than 30 subsidiaries and over ten production plants as well as about 570 commercial and service partners. This is what makes us your highly skilled and integrated partner. Use our comprehensive and unique expertise in the industry.

You can find additional information at: www.kraussmaffeigroup.com

You can find additional information about KraussMaffei at: www.kraussmaffeicom

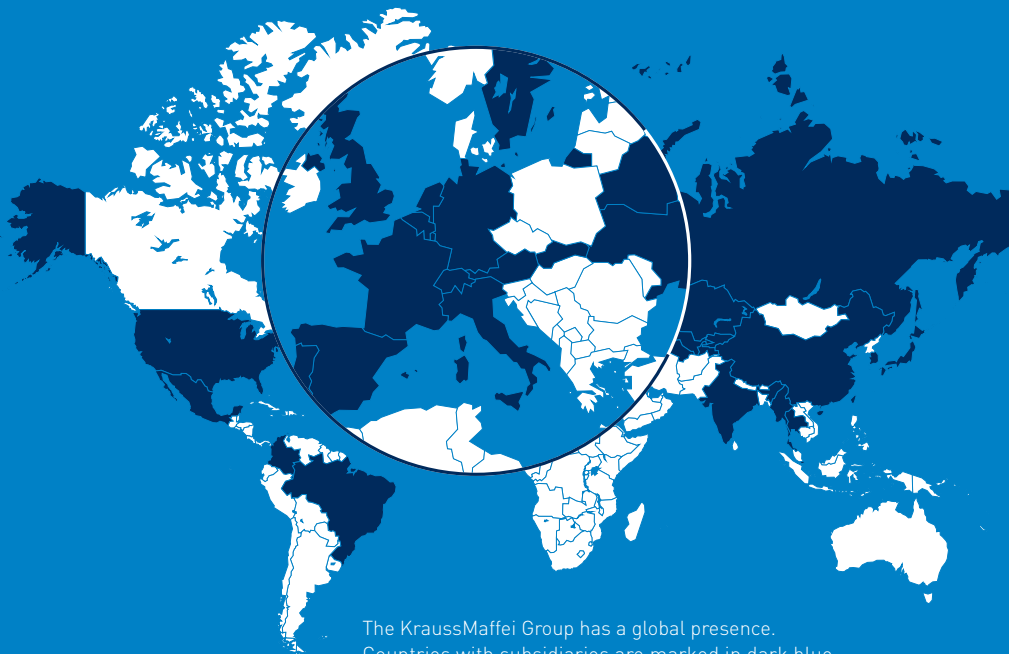

The KraussMaffei Group has a global presence. Countries with subsidiaries are marked in dark blue. In the white-colored regions, the Group is represented by over 570 sales and service partners.

FiberForm lightweight parts

The perfect combination of thermoforming and injection molding

Parts used as alternatives to metal or traditional thick-walled plastic parts need to be lightweight yet highly functional. These days, conserving resources is a top priority and lightweight functional parts are therefore highly sought-after, particularly in the automotive industry.

FiberForm technology by KraussMaffei enables you to produce complex structural components using a fully automated process – efficiently and with noticeably short cycle times. The combination of thermoforming one or several semifinished products (organic sheets, thermoplastic tapes, etc.) and injection molding thermoplastic materials opens up completely new design possibilities and therefore market potential.